



# KF5000

## PARTS AND INSTRUCTION MANUAL

Marking and Decorating Systems

1 MAIN ST. WHITINSVILLE, MA 01588 PHONE: 508-528-2000

FAX: 508-520-7129

NATIONWIDE PARTS & SERVICE

## Table of Contents

<u>Description</u>	<u>Page</u>
Warranty	3
Warning	4
Standard Test of Safety Items	5
Advantages of Hot Stamping	6
Vertical Stamping	7
Press Installation/Set-up	8
Pneumatic Controls	9
Understanding Toggle Action	9
Ram Adjustment	10
Holding Stamping Dies & Type	12
Adjusting Stamping Height (Metal & Silicone Dies)	12
Foil Selection & Installation	13
Electric Leaf Pull (KF 5000)	14
Heat Transfer Indexers (KF 5000)	15
Hot Stamping Troubleshooting	16
Maintenance	17
Temperature Control	18
Controller-GE-MPL-01-B	19
Controller-GE-MPL-02-B	20
Heat Transfer Control Setup	21
Machine Drawings	22
Pneumatic Diagram	35

## Warranty

- The company warrants the original purchasers of all products manufactured by it. Such that products will be free from defects of material or workmanship for a period of 12 months from the date such products are shipped from its plants, provided that the Buyer gives prompt written notice of such defects. Said warranty is to remain in effect it and only if such products are used in accordance with all instructions as to maintenance and operation set forth in manuals and instruction sheets furnished by the Company. In no event shall this warranty be deemed to cover or obligate the Company in any way regarding items or components not actually manufactured by it.
- This warranty is made in lieu of all other warranties express or implied including merchantability. No promise or affirmation of fact (including but not limited to statements regarding capacity or performance of a machine) shall constitute a warranty by the Company, or give rise to any liability of the Company.
- The Company's liability under this warranty is limited to delivering to the Buyer F.O.B. the Company plant in Franklin Massachusetts, replacements of any equipment or parts determined by the Company to be defective. The Company's guarantee with respects to equipment manufactured by others will be the same as that of the manufacturer. In no event will the company be liable for damages (direct, consequential or otherwise) or injuries sustained as the result of defective workmanship or material in the equipment.
- Buyer shall use, and shall require its employees to use all safety devices, guards and proper safe operation procedures as set forth in manuals or instruction sheets furnished by the Company. Buyer shall not remove or modify any such device or guard or warning sign. Buyer shall not permit any person other than required operating personnel to remain within ten feet of any machine or accessory manufactured by the Company during operation thereof. If Buyer fails to strictly observe each and every one of the obligations set forth in this paragraph with regard to any of the company's products. Buyer agrees to indemnify and save the Company harmless from any liability or obligation, incurred by the company to person's injured directly or indirectly in connection with the operation of such products.
- Buyer shall notify the Company promptly, and in any event within 30 days of an accident or malfunction involving the Company's products which result in personal injury or damage to property and shall cooperate fully with the Company, in investigating and determining the cause of such accidents or malfunctions. In the event that Buyer fails to give such notice to the Company or so cooperate, Buyer agrees to indemnify and save the Company harmless from any claims arising from such accident or malfunctions.

## Warning

- A hot stamping press applies heat and high pressure to the article being marked. Care should be taken by the operator to keep hands free of the stamping area whenever the equipment is connected to air and electricity. When handling large articles, hold them by the sides so that hands are not under the stamping head. **When handling small parts, a manual or air slide table should be used during stamping and loading parts onto fixtures should take place away from the stamping area.** Always remember that the die in a hot stamping press is very hot. Because of this, the heated head area, die holders, and dies should be handled with great care to avoid burns. Heat resistant, insulated gloves or hot pads should be made available for handling dies.
- **A transparent safety gate should be installed to protect the operator.** Because this press is so versatile, it is impossible for the manufacturer to supply a universal safety gate or slide fixture. For further information or quotations on custom parts loading devices or safety gates, contact the manufacturer.
- Presses are furnished with dual hand buttons wired so that an operator must depress both to initiate a cycle. An anti-tie down system is a standard component except where automatic loading features are provided with custom systems.
- **Any attempt to alter the wiring or construction of this press, disconnecting or disabling the two-hand trip or anti-tie down circuits is completely unauthorized and may result in serious injury (or death) to the operator.**
- Machines are thoroughly tested before shipment. Please remember that any machine can malfunction for a number of reasons beyond the manufacturer's control. **The standard safety test outlined in the appendix should be conducted at the start of each shift** and should be conducted by a thoroughly trained operator knowledgeable of all safety system operations. If any malfunction is detected, immediately turn off press and notify the shift foreman. Do not use press until the detected problem has been remedied.
- Remember to disconnect all air and electrical lines when performing repairs or doing maintenance on equipment to prevent accidental actuation of the stamping head.
- New operators should be trained in the safe operation of this equipment before use.

## Standard Test of Safety Systems

**For presses equipped with optional Lite Touch sensors, touch finger area to activate press for all steps below.**

- 1) Connect air and electrical supplies according to machine requirements.
- 2) Turn power On.
- 3) Set dwell time to 1.00 seconds.
- 4) With head switch in Off position, depress and hold left-hand button.
- 5) Wait 3 seconds and depress right hand button. Press should not actuate.
- 6) Repeat test, pressing right hand button first and left second. Press should not actuate.
- 7) Depress both buttons simultaneously. Press should not actuate.
- 8) Turn head switch to On position.
- 9) Repeat steps 5 & 6. Press should not actuate.
- 10) Turn head switch to Setup position.
- 11) Repeat steps 5 & 6. Press should not actuate.
- 12) Depress both buttons simultaneously and immediately release. Press should start to actuate and return to up position when buttons are released.
- 13) Depress both buttons simultaneously and keep pressed while head descends to stamping position. Once head is down, release buttons. Head should stay down.
- 14) Turn head switch to Off position. Head should return to up position.
- 15) Turn head switch to On position and set-up switch to Run position.
- 16) Repeat steps 5 & 6. Press should not actuate.
- 17) Depress buttons simultaneously and keep depressed while head descends to stamping position and release buttons. Head will stay down while dwell time elapses and then return to up position.

## **Advantages of Hot Stamping**

### **Dry Method**

Hot stamping is a dry decorating method that requires no ink or clean up. There are no concerns with EPA or Fire Safety rules when hot stamping as it does not contain any hazardous materials.

### **Save Time**

Printed parts are immediately available for handling and packaging, allowing faster product turn-around.

Set-up time is minimal, simply consisting of changing the roll of foil or die.

### **Variety**

Hot stamping can be used on a wide range of materials. Most plastics, wood, book cloth, and leather

Hot stamping is the only decorating method that will apply a permanent gold and silver metallic finish. Foils are available in a wide range of colors and finishes including matte, gloss, brushed, chromium and wood grain.

Pre-printed heat transfers will accomplish multi-colored graphics to a variety of materials such as plastics, glass, fabrics, etc.

### **Surface Configurations**

Hot stamping foils can be applied to a variety of surface configurations such as flat, cylindrical, spherical and contoured parts as well as raised graphics or beaded surfaces.

### **Permanent Results**

The hot stamping process produces graphics that have maximum adhesion and abrasion resistance due to the thermal bonding that takes place during stamping.

## Vertical Stamping

Vertical stamping is the most commonly used hot stamping method. It is ideal for applying foils or pre-printed heat transfers to smaller areas of flat or slightly contoured parts and to a maximum of 90 degrees on the circumference of cylinders or spheres.

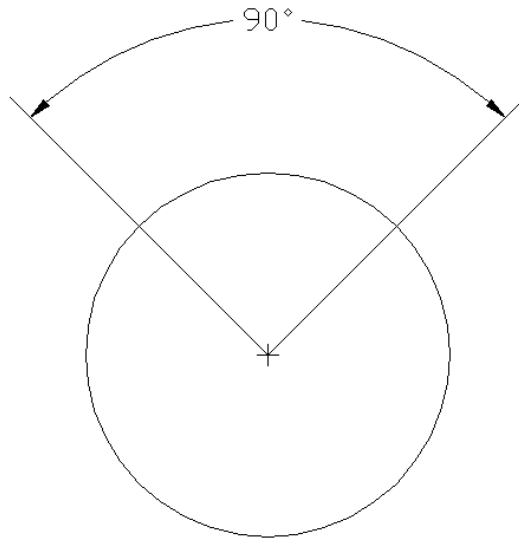

In most thermoplastic foil vertical stamping applications, a silicone rubber die is mounted to the heater head of the vertical acting machine and positioned directly over the area of the part to be decorated. Dies will be constructed of heat stable silicone rubber bonded to aluminum. Silicone dies are available in a range of durometers and thickness' to accommodate various part materials and configurations. The image to be stamped are raised on the die surface at a minimum of 1/32" and are heated to temperature near the melting point of the plastic substrate, usually in excess of 350 degrees F.

Hanging directly underneath of the die, held by two stripper bars, is the hot stamp foil. Typically, 1-1/2" of space is required to be left between the foil and hot die face to ensure proper release of the foil.

## Press Installation/Set-up

### Unpacking/Inspection

- Upon receipt of press, remove upper crate and inspect to be sure no damage has occurred during shipping. If there is visible damage, please notify your shipping contractor immediately.
- Machine should be permanently mounted to a level, secure bench or table (or optional floor stand) using the mounting holes provided. It should be at a level that allows the operator to press the hand buttons while forearms are parallel to the floor. Be sure to allow enough space around the machine for maintenance, set-up and production. If not using the KF floor stand, care should be taken to ensure that the bench is large enough and sturdy enough to prevent collapse or tipping over.

### Air/Electrical

- Connect air and electrical supplies according to machine requirements. Air supply requires a minimum 3/8" line to prevent air starvation when operating press. Pneumatic quick connect should also be 3/8". Recommended air pressure is ordinary shop air. Do not operate over 125 PSI.

### Air Line Filter

- The air filter cleans incoming air removing debris and moisture that is common to air lines. Filter is self-draining and this feature may become inoperative if the float is clogged with particle matter from the air line. **Be sure to clean air filter daily and exhaust all moisture before and after operation.**

## IMPORTANT

**This step must be completed prior to operating the machine.  
For machines with Lubricators only!**

### Lubricators

- Press is shipped with lubricator(s) empty. Fill all bowls 3/4 full with **SAE #10 Non-Detergent Lightweight machine oil only**. Fill all pneumatic leaf pull systems, automation devices and slide tables that require oil (Oil may be ordered through K/F Systems.)
- Adjust each lubricator so one drop of oil falls through sight glass approximately every 50-60 cycles.
- Following manufacturer's instructions located in appendix, regulate oil flow until small amounts of oil are seen at the muffler on the exhaust port of each air valve.
- Do not allow the oil to become emulsified. Loss of clarity indicates contamination. **If oil becomes contaminated, change it immediately.**



## Pneumatic Controls

### Pressure Regulation

- Press will operate at pressures between 40 and 125 pounds per square inch.
- Pressure should be adjusted to give a firm squeeze on the part and will increase as the stamping area and hardness of the material increase.

### Speed Control

- Speed of the up and down stroke can be controlled at the main valve.
- Cylinder speeds are controlled by the exhaust flow, not the intake flow. On toggle presses, solenoid valve is mounted vertically with speed control mufflers in the exhaust ports. The upper muffler controls the head's downward travel. The lower muffler controls the heads upward travel.
- The main cylinder has a cushion adjusting screw on the bottom end cap facing the operator. This screw should be set between 1 ½ and 2 full turns out from the closed Position. When the heater head comes up, this adjustment causes the head to slow Down as it comes to its up position.
- Turning the screws clockwise slows the stroke.
- Screws should be locked after adjustments are made with the check nuts provided.

## UNDERSTANDING TOGGLE ACTION

The 5000T, and the 7000T presses use a toggle linkage system to deliver the high pressure needed for hot stamping. The nature of toggle action is to develop maximum force when the head reaches its maximum stroke (full toggle).

Referring to the toggle diagrams, diagram A-2 shows the head meeting the part at maximum stroke, which exerts maximum stamping pressure. If the table is set so that this occurs, and the first part is taken out and replaced by a part that is thinner, the head will exert no pressure on the thinner part. The thinner part will not receive the same impression, because the head can not extend farther than maximum stroke.

NOTE: If work does vary in thickness, adjust table so that imprint occurs just before the linkage reaches full toggle position (diagram A-1). This adjustment allows for consistent impressions on parts that vary in height (or thickness), while stamping at or near maximum pressure.

## RAM ADJUSTMENT (TOGGLE PRESSES)

Test the upper ram every 6 months to be sure it is adjusted properly. Testing should be done at operating temperature plus 25 degrees, to check for excessive play or binding.

Your controller has a set-up mode for lowering the heating head for testing purposes.

If the press is binding, first make sure that other parts of the machine are not the source of your trouble, before loosening the ram bolts. Check the links and pins, making sure all joints are lubricated properly. Make sure the ram is greased, also.

High temperature grease must be used on the ram, and should be used on all of the links and pins. The proper grease can be purchased from Kensol-Franklin. Be sure to clean off as much of the old grease as you can, it may contain dirt and other contaminants that can damage the ram and gibs, etc. A clean press is also much easier to work on.

When the ram is down, inspect the wear surfaces for signs of damage. If the ram and gibs show signs of binding (scratches, grooves or pitting), they should be disassembled and repaired, or replaced. If the ram is loose, then you may start the adjustment procedure. Before anything else, the front cover must be removed.

To tighten the ram, you must loosen the two bolts that hold the right gib, that is the adjustable side. The left gib is tightened against the frame, and should not have to be loosened. Next, you must loosen the nuts that hold the two set screws, located on the right side of the frame. If these setscrews are tight, you must back them out at least one full turn to ensure that they are clear of the gib. At this point, you can retighten the two gib mounting screws, snug, but not fully tight. Now, begin turning the setscrews in until they stop, and then another  $\frac{1}{4}$  of a turn. This will push the right gib in contact with the ram, starting to close up the gap.

At this time, you may switch your controller back to “run” mode, and test the machine for smooth operation. You may also shut off your air, and test manually, with a handle inserted into the hole on the end of the main shaft. The next time the head is down, recheck the ram for tightness. You may have to turn the adjusting screws in slightly, several times before the play is gone. If the ram becomes too snug, try tapping the ram plate on the edges with a soft mallet (plastic, rawhide, etc.) a few times, and try moving it again. If the ram moves smoothly all the way up and down, you should be finished with the adjustments. Remember to retighten the gib mounting screws and check it again. If you tighten all of the screws and the ram is now sluggish, you might have to back off the setscrews slightly, and try it again. Too much play will make it hard to get a clear impression, too little play will cause the ram to chatter, or hesitate.

If the heating head is not level, and doesn't lay parallel to the worktable, you should make sure the ram is set correctly, before you attempt to level the head. Replacing the links and pins should not affect your final adjustments, but if you are in doubt about the condition of your links, check the ram link when the ram is loose.

## TOGGLE DIAGRAMS

### Operation of press

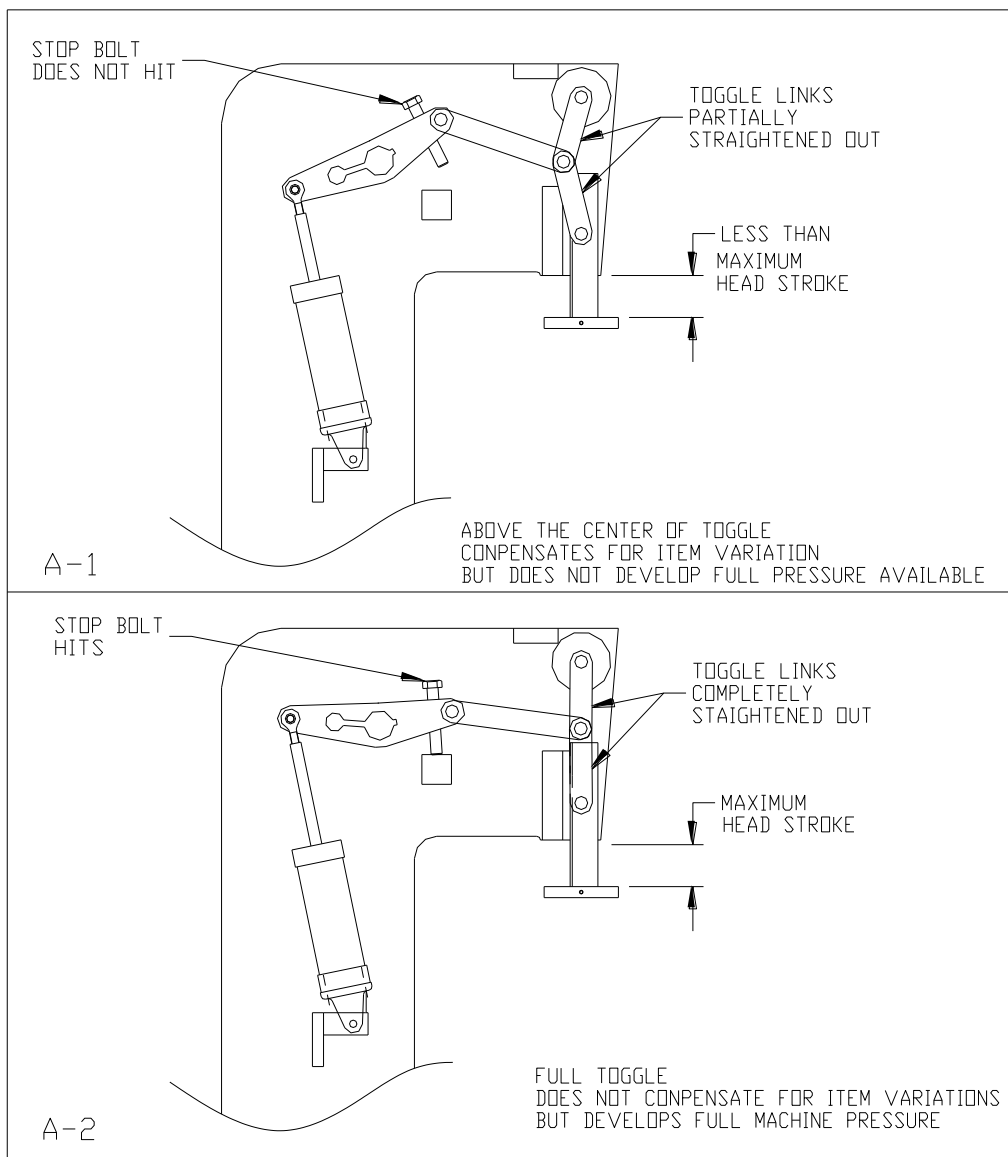

## Holding Stamping Dies and Type

A variety of dies and hand set types (slugs, etc.) can be used with your press. For flat, un-mounted dies the dovetail that comes with the press or an optional hot-plate chase would be used. This is a solid block of metal with machined parallel sides mounted to a dovetail. Dies may be attached by using screws, or Die Bond Tape, a heat sensitive adhesive. Steel, brass, zinc, magnesium and silicone rubber dies are frequently used with hot plate chases. The optional 4 Wall Chase is used for hand set type, lino type, Ludlow slugs or type high dies. Occasionally, flat thin photo engraved or hand engraved dies, mounted on metal blocks are held in the 4-wall chase.

- Slide dovetail chase into the right or left side of the 2" x 4" or 3" x 6" head or into the front of the 6x8" or larger heads.
- Position die using the adjustable stop provided on the head.
- Slide the holder to the stop and tighten the locking clamp. When tightening the clamp, use moderate pressure only. If too much tightening pressure is applied, especially to a cold holder, expansion can cause damage to the heater head.

## Adjusting Stamping Height

(The distance between the die and the part to be marked)

The clearance between the die and the bed of the press can be adjusted as follows:

- Reduce the pressure to 40 PSI
- Place the set-up switch in the SET-UP position.
- Loosen the four bolts or handles at rear of head assembly.
- Make sure there is 2-3/4" of daylight under the die so the die will not be damaged by hitting the part or fixture. Turn the elevating handle to raise or lower the table.
- Tighten the head assembly using the four bolts/handles.
- Adjust the micrometer depth stop so there is 2-1/2" of stroke available.
- Upon actuation, the head will descend and stay down. The die should be above the part on its fixture. Place the setup switch in the RUN position and gradually raise the worktable until the die begins to mark the part.

**Always place foil between the die and the part to keep melted plastic from filling and damaging the die.**

## Metal Dies

With metal dies, adjust the die to be lower than the top surface of the part to be stamped but higher than the fixture. This allows the die to put enough pressure on the part to make a good imprint, preventing damage to the die or fixture if the machine is actuated with no part on the fixture. Next, adjust the pressure to provide the desired result. With this setting method, variations in overall part thickness will not affect the result, however, variations from cavity to cavity creating different angles between surfaces may.

## **Silicone Rubber Dies**

For Silicone Rubber dies, follow the same procedure at much lower pressures. With small contact area between die and part, it may be necessary to use the depth stop to limit die distortion & wear.

## **Foil Selection**

Hot stamping foil is available in a wide variety of colors and designs. The more common foils include Metallic and pigmented finishes, but designs such as wood-grains, brushed effects, continuous patterns and chromium are available and frequently used. Be sure that the foil you have selected will be compatible with the part material to ensure proper adhesion. Should you encounter difficulties with foils, you may send sample parts and artwork to our Technical Service Department for evaluation and suggestions.

## **Hot Stamp Foil Installation**

- Be sure that the disc & locking collar on foil holder bar are in place and locked.
- Load foil onto foil holder bar.
- Make sure the foil will unwind in a counterclockwise rotation, with the dull (-coated) side facing the part to be stamped.
- Align foil with the mounted hot stamp die.
- Place supply disk onto bar and slide compression spring against disk. Place locking collar against spring and use handle to lock collar in place.
- Be sure foil is centered and tighten the clamps near the support bar while applying a small amount of pressure to the foil roll. Make sure that the foil is wide to cover the entire die and overhang approx. 1/4" on sides.
- Thread foil as follows: From holder bar→under in-feed & out-feed stripper bars→up over knurled roller(loosen foil pull release disk to separate the knurled and rubber rollers for ease during feeding)→down between knurled and rubber roller→wrap onto the rewind roller assembly. Be sure it is properly wrapped on the rewind roller to prevent spent foil from mis-feeding.
- Adjust the stripper bars to position the foil so it is not in contact with the die and be sure that the bars are level. If the foil travels to the side, adjusting the stripper bars will straighten it.

## Electric Leaf Pull (KF 5000)

The amount of pull is set on the control box by pressing the F1 key for the desired length. Press clear, enter value for pull, press enter. Use same sequence for foil pull delay. (Refer to programming instructions pg.19 for more information.)

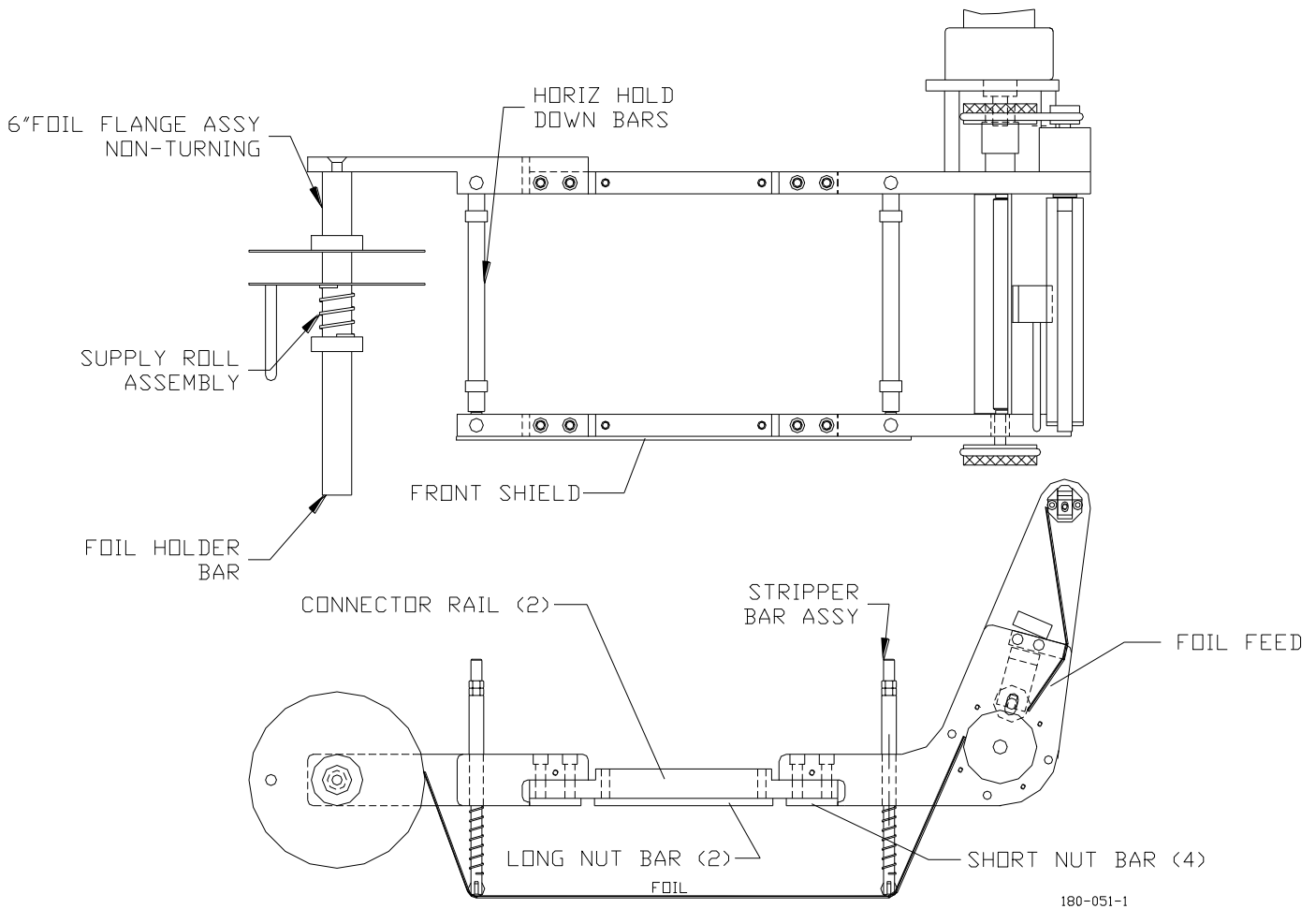

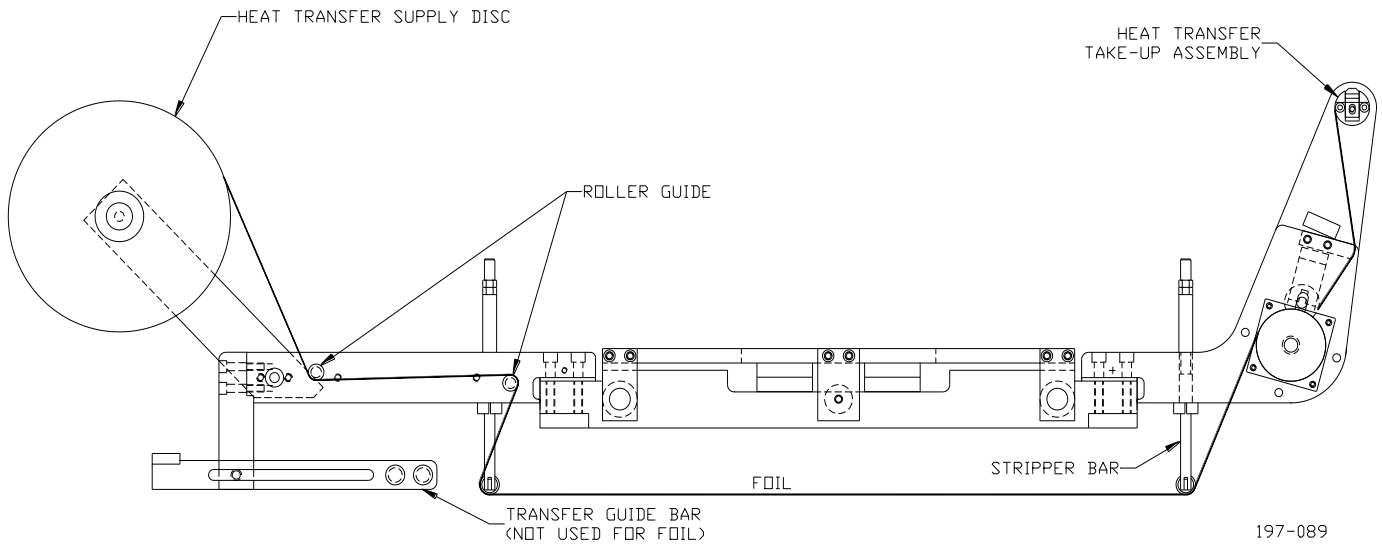
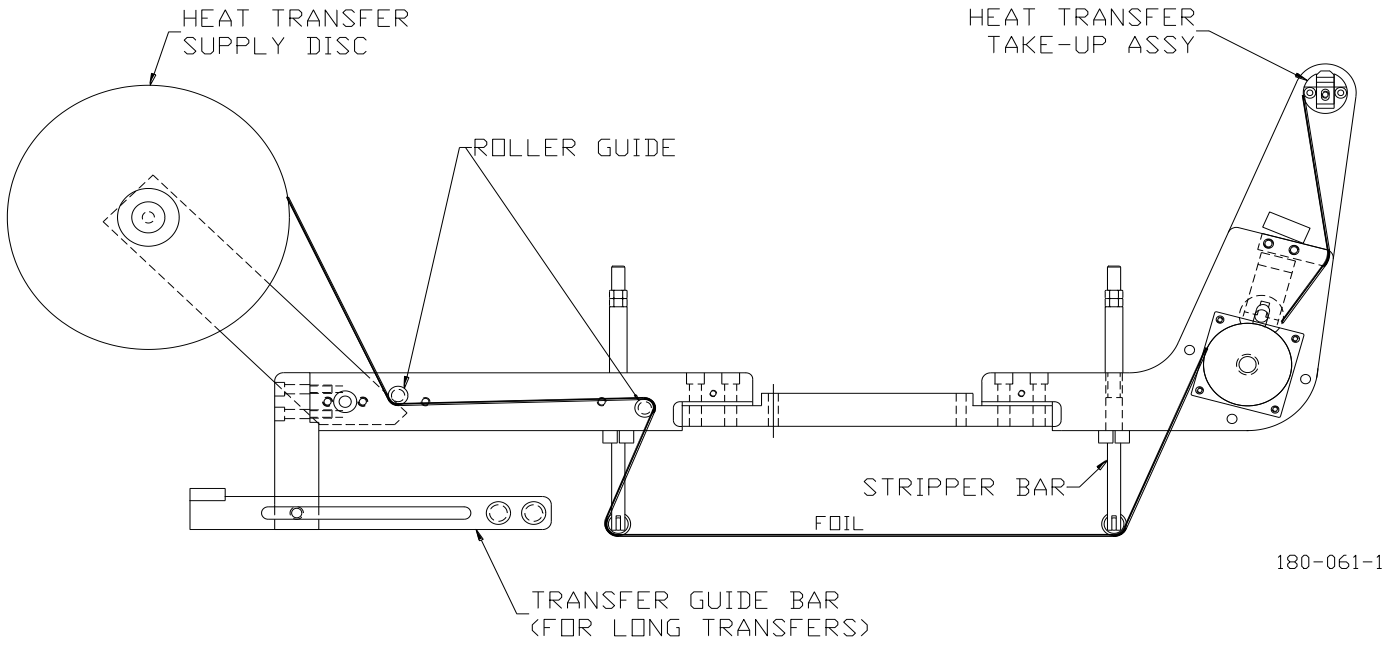

## Hot Stamping Troubleshooting

Problem	Cause	Solution
Incomplete hot-stamped image.	Uneven die to part contact.	Reposition fixture so decorating surface is parallel to a flat die or conforms to a contoured die.
	Part contamination.	Eliminate the use of flow agents, anti-static solutions and/or silicone based mold releases.
	Dust particles on decorating surface.	Clean surface with white cotton cloth or glove or use a destat system.
	Poor fixture support permitting the part to flex under the force of the machine.	Redesign fixture to provide rigid support under surface of part and/or ensure that mandrel type designs do not deflect.
	Air entrapment between foil and part surface.	Redesign die face to include convex crown.
Over stamping of image.	Too much pressure.	Decrease stroke length and/or reduce machine pressure.
	Die face is too hot.	Reduce temperature setting.
	Dwell time is too long.	Reduce dwell time setting.
	Sinks in decorating surface.	Use make-ready beneath the part in the areas that are hitting light and adjust pressure accordingly.
	Variations in wall thickness from part to part.	Try a duel durometer silicone rubber die.
Hot stamped image appears blurry.	Pressure may be too low.	Change stroke length and/or increase pressure.
	Part contamination.	Eliminate the use of flow agents and/or silicone based mold releases.
	Die face temperature too low.	Increase temperature setting.
	Dwell time is too short.	Increase dwell time.
	Foil stripping conditions.	Slow head retraction speed and/or use head-up delay where applicable.
	Foil is effected by heat of die prior to stamping.	Use before/after foil selector to advance foil just prior to stamping
Poor foil to part adhesion.	Insufficient die surface temperature.	Increase temperature setting and/or move the thermocouple closer to the die face.
	Dwell time is too short.	Increase dwell time setting.
	Part contamination.	Eliminate the use of flow agents, anti-static solutions and/or silicon based mold releases.
	Dust or particles on decorating part surface.	Clean surface with white cotton cloth or glove or use a destat system.
	Foil stamping problem.	Switch to a different foil formulation.



## **Maintenance**

- At the start of each shift, perform the Standard Test of Safety Items listed in this manual to be sure that the machine is properly functioning. If any problem is detected, disconnect the press until corrected.
- Press should be kept clean and free of dirt and contaminants.
- Pay attention to the amount of moisture in the air filter transparent bowls.
- Use a premium grade of high temperature grease on the main RAM.
- No lubrication is required on the leaf pull bearings as they are self-lubricating Teflon.
- Occasionally, grease the die clamping screw and die pivot clamp with high temperature grease.

# TEMPERATURE CONTROL

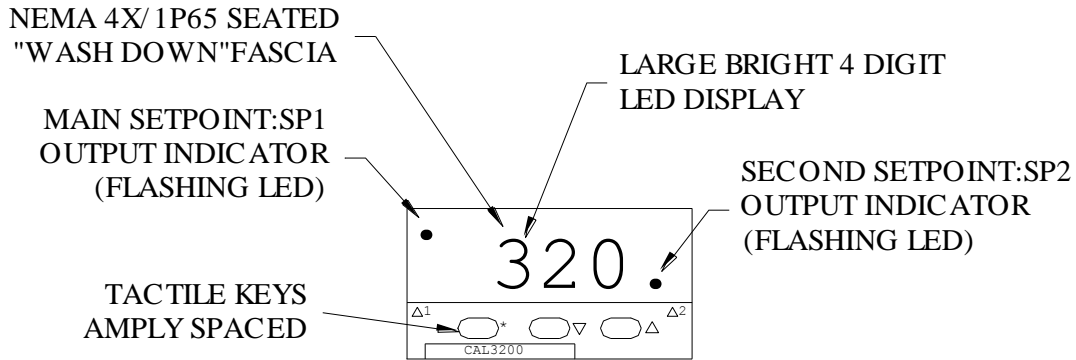

## DISPLAYING

NORMAL DISPLAY  
PROCESS TEMPERATURE

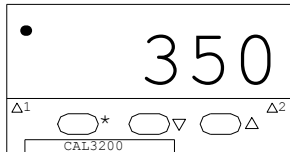

ADJUSTMENT OF SETPOINT

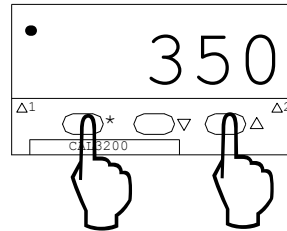

PRESS AND HOLD \* BUTTON

ADJUST T° UP ▲

DOWN ▼

RELEASE \* BUTTON

**PROGRAMMING INSTRUCTIONS**  
**STANDARD ELECTRICAL SYSTEM (GE-MPL-01-B)**

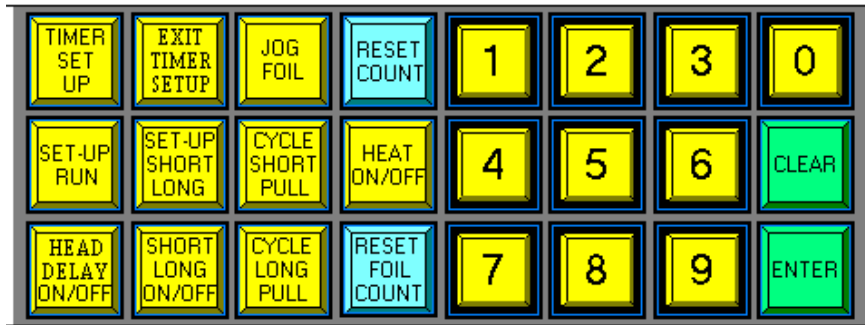

**To change all values:**

Press clear, enter new value, press enter.

**Timer set up**

Sets up head, dwell, foil pull delay, foil pull time,  
 Optional: head up distance, and head up delay time.

**Set-up/run**

Toggles press between run & set-up mode  
 Run mode, press will operate in normal mode  
 Set-up mode, head will come down and stay down until set-up/run is toggled again, returning  
 press to run mode.

**Head delay on/off**

Turns head up delay on & off. **Note;** this is an optional feature and may not be equipped on all presses.

**Exit timer setup**

Lets operator exit timer screens at any time

**Set-up short long foil pulls**

Sets up short foil pull time and number of repeats required, followed by long pull time required

**Short Long on/off**

Turns short/long foil feature on & off

**Foil jog**

Jogs foil while button is pressed

**Cycle short pull**

Cycles foil amount entered in short foil pull timer

**Cycle long pull**

Cycles foil amount entered in long foil pull timer

**Reset count**

Resets cycle counter, (press and hold button for 2 seconds)

**Heat on/off**

Turns heat on & off

**Reset foil count**

Resets foil count (short/long) sequence.

**PROGRAMMING INSTRUCTIONS**  
**STANDARD ELECTRICAL EYE SYSTEM (GE-MPL-02-B)**

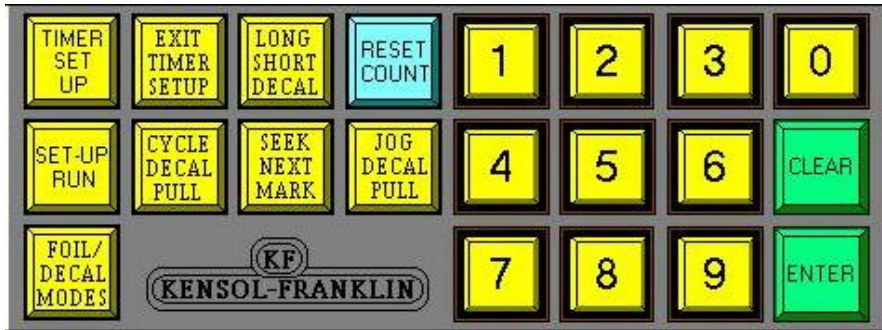

**To change all values:**

Press clear, enter new value, press enter.

**Timer set up:**

Sets up head, dwell, foil pull delay, foil pull time,  
Optional: head up distance, and head up delay time.

**Exit timer setup:**

Returns to main menu

**Foil/decal modes:**

Toggles between standard foil pull, and light and dark decal modes

**Long short decal:**

Short decal uses slow speed only to find eye mark. Long decal uses both fast speed and slow speed to find eye mark.

**Heat on/off:**

Turns heat on & off

**Jog decal pull:**

Jogs foil while button is pressed

**Cycle decal pull:**

Cycles foil amount entered in foil pull timer

**Seek next eye mark:**

Cycles foil to next eye mark

**Set-up/run:**

Toggles press between run & set-up mode

Run mode, press will operate in normal mode

Set-up mode, head will come down and stay down until set-up/run is toggled again, returning press to run mode.

**Reset count:**

Resets cycle counter, (press and hold button for 2 seconds)

Note: Numbered speed control knob is used for decal mode only. This sets the slow speed only used to find the eye mark.

## **HEAT TRANSFER INDEXER**

### **ELECTRICAL CONTROL – SETUP**

#### **ELECTRIC EYE – TRITRONICS CONTROL:**

Initial setup - fibers should be adjusted so that there is a  $\frac{1}{4}$  space between fiber optic cables. Place transfer so that the fibers are between the eye spots. Contrast indicator scale should read 8 or above. If less than 8 remove plastic plug on top of scanner and adjust internal pot with a small screwdriver so that a reading of 8 is obtained. If the carrier is Kraft Paper you may have to move the fiber optic cables closer together to obtain a reading of 8.

Next place the eye spot between the fibers. The contrast indicator should be 3 or below. The switch over point on the Tritronics control is 5 – minimum 2 points either side of 5 is preferred for consistent results.

#### **FAST PULL TIME:**

High speed advance between eye spots. Adjust time so that the transfer drive switches to low speed approximately 1” before the next eye spot.

#### **SLOW SPEED:**

Set adjustment knob to slowest speed (#5) for maximum registration accuracy.

#### **SETUP: ON ANALOG CONVERSION UNITS:**

Adjust actuation switch cam so that transfer is vertically stripped from part before high speed advance begins.

#### **ON MICROPROCESSOR CONVERSION UNITS:**

Press web or decal jog button to test web speed and registration – make adjustments to obtain a smooth transfer advance. On microprocessor based controls press decal seek button to advance web in slow speed to the next eye spot

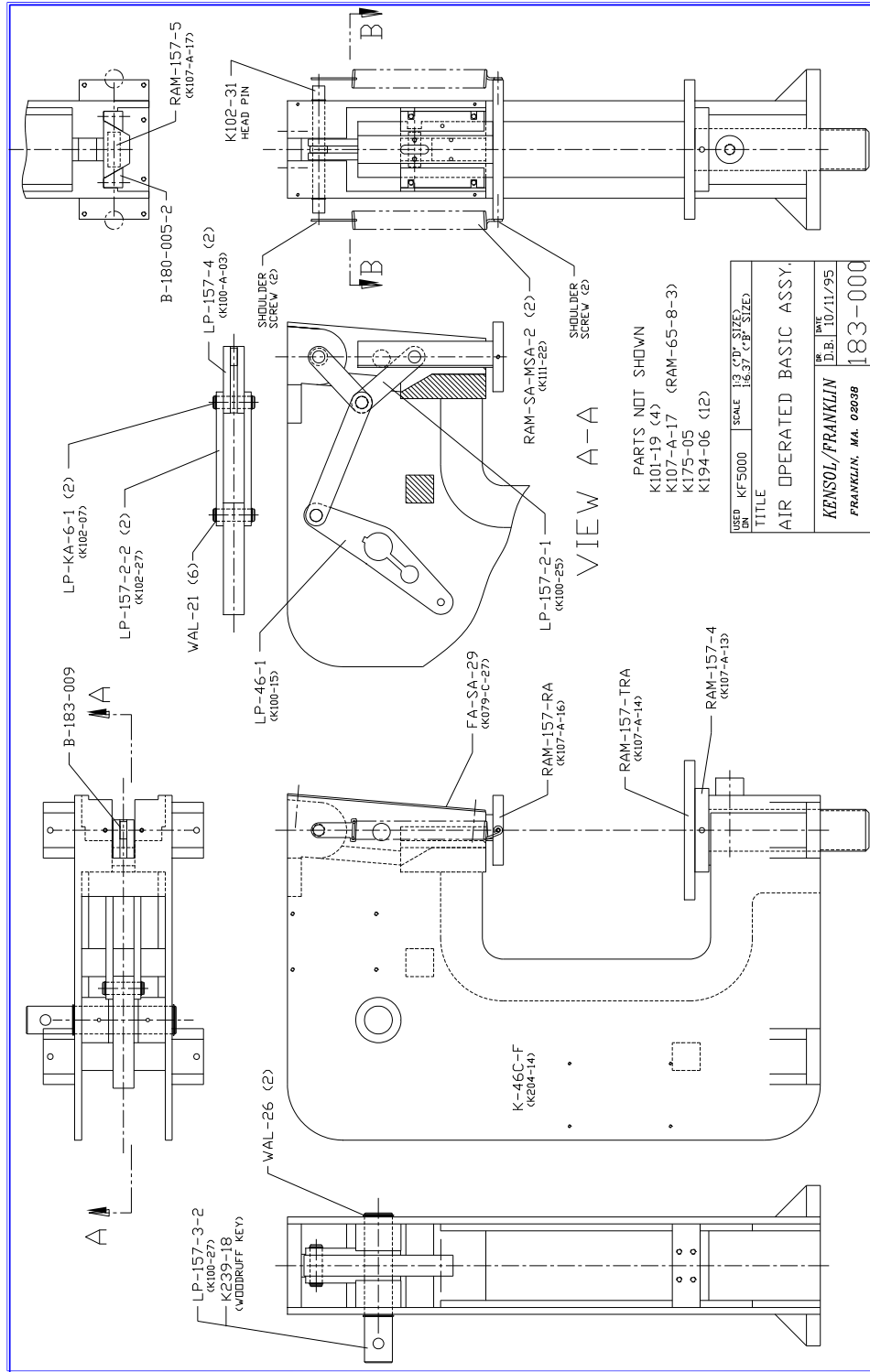

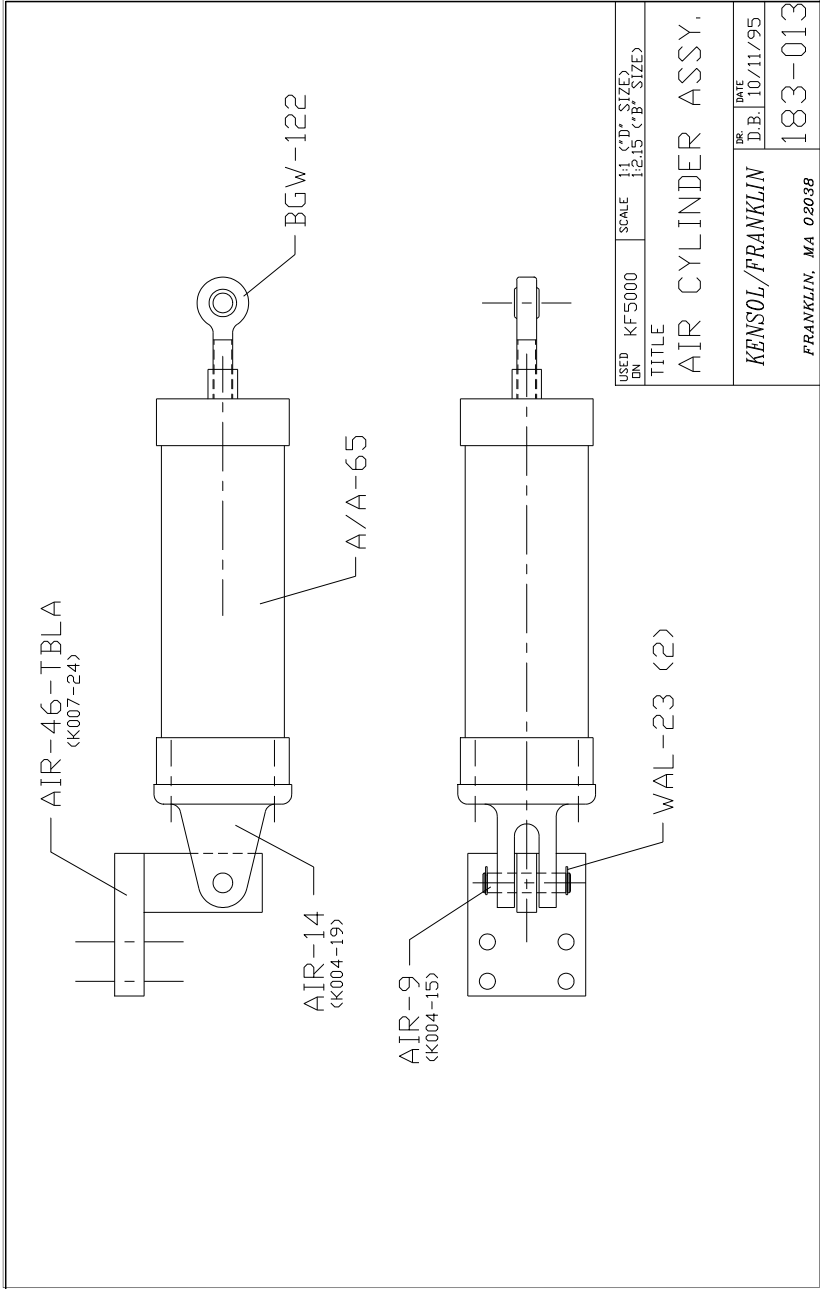

USED DN	KF5000	SCALE	1:1 (C'D' SIZE) 1:2.15 (B' SIZE)
TITLE			
AIR CYLINDER ASSY.			
KENSOL/FRANKLIN		DATE	10/11/95
FRANKLIN, MA 02038		183-013	

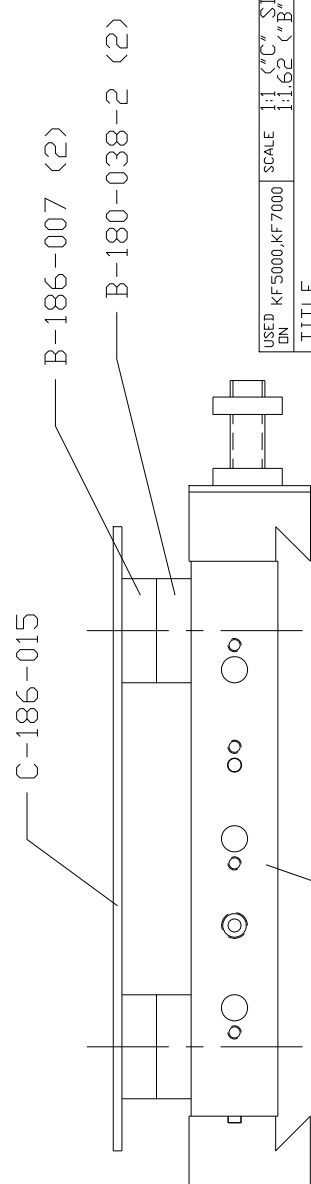
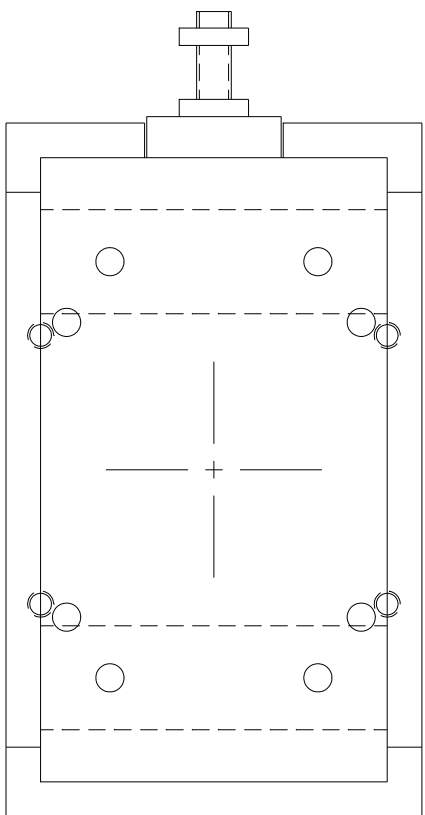
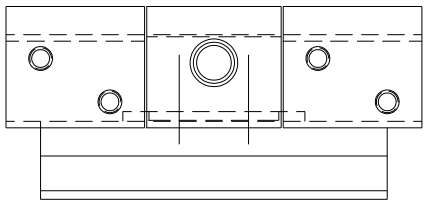

130-02030

USED DN	KF5000, KF7000	SCALE	1:1	( <sup>1</sup> / <sub>2</sub> " C" SIZE)
			1:1.62	( <sup>1</sup> / <sub>2</sub> " B" SIZE)
TITLE				
6X8 HEATER HEAD ASSY.				
KENSOL/FRANKLIN		DR.	DATE	
FRANKLIN, MA 02038			10/12/95	
		186-001-1		



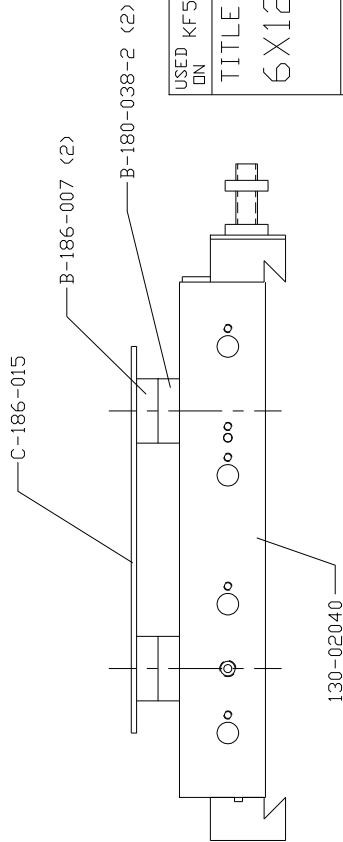
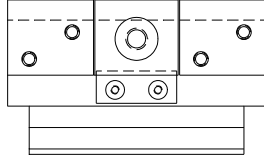
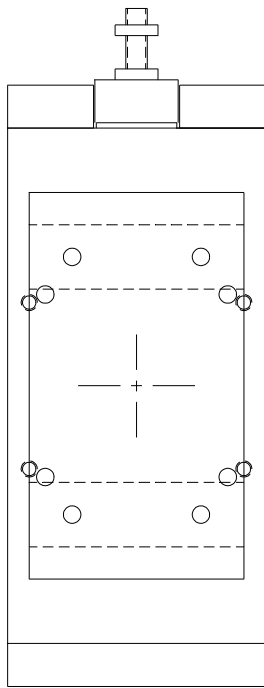

USED KF5000, KF7000 SCALE 1:1 ("D" SIZE)  
 DN 1:2.15 ("B" SIZE)

TITLE  
 6X12 HEATER HEAD ASSY.

DR:	DATE
D.B.	10/12/95
KENSOL/FRANKLIN	
FRANKLIN, MA 02038	
186-002	

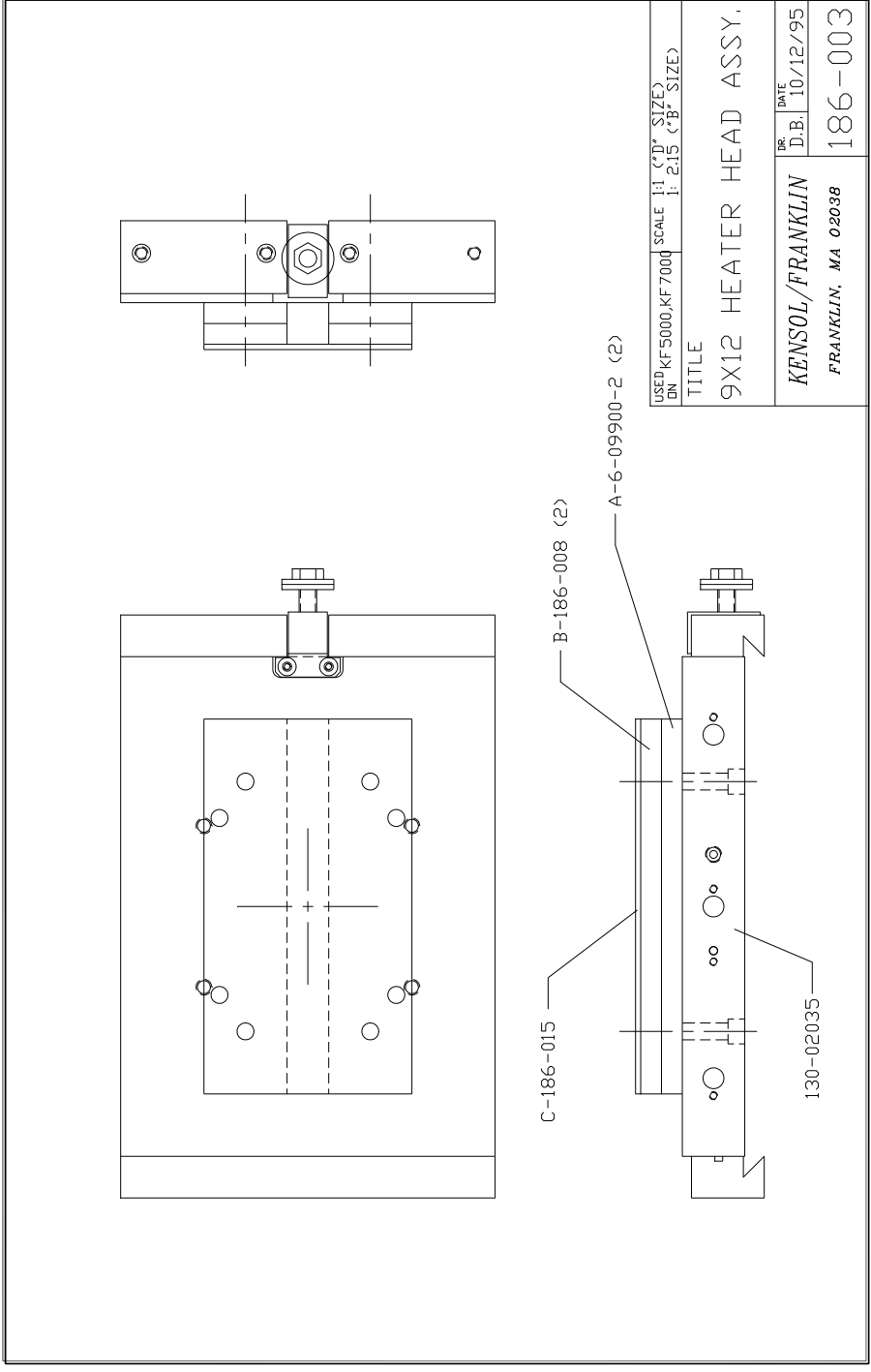

USED DN	KF 5000, KF 7000	SCALE	1:1 (A, D, SIZE) 1: 2:15 (A, B, SIZE)
TITLE			
9X12 HEATER HEAD ASSY.			
FR. D.B.		DATE	
KENSOL/FRANKLIN		10/12/95	
FRANKLIN, MA 02038		186-003	

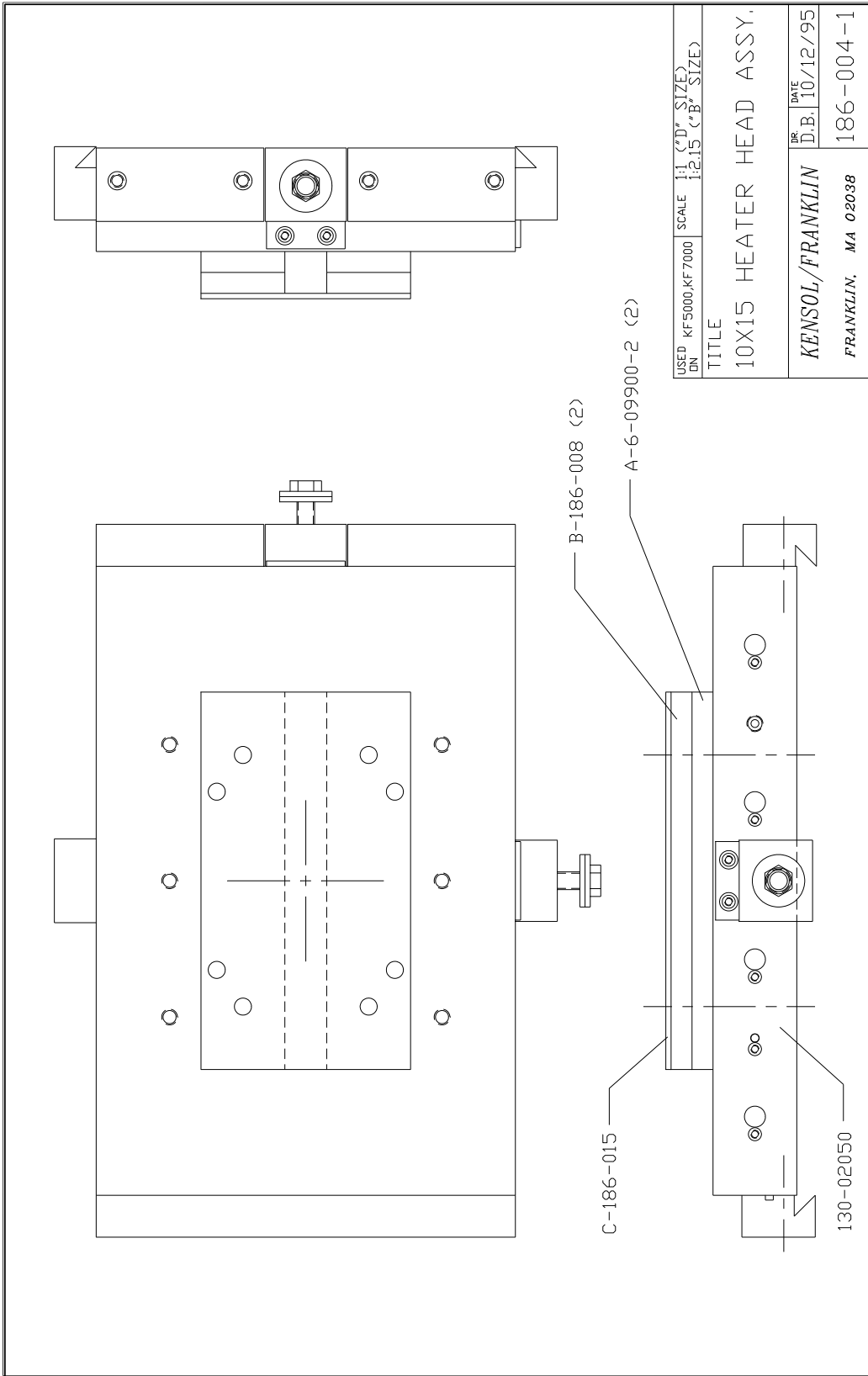

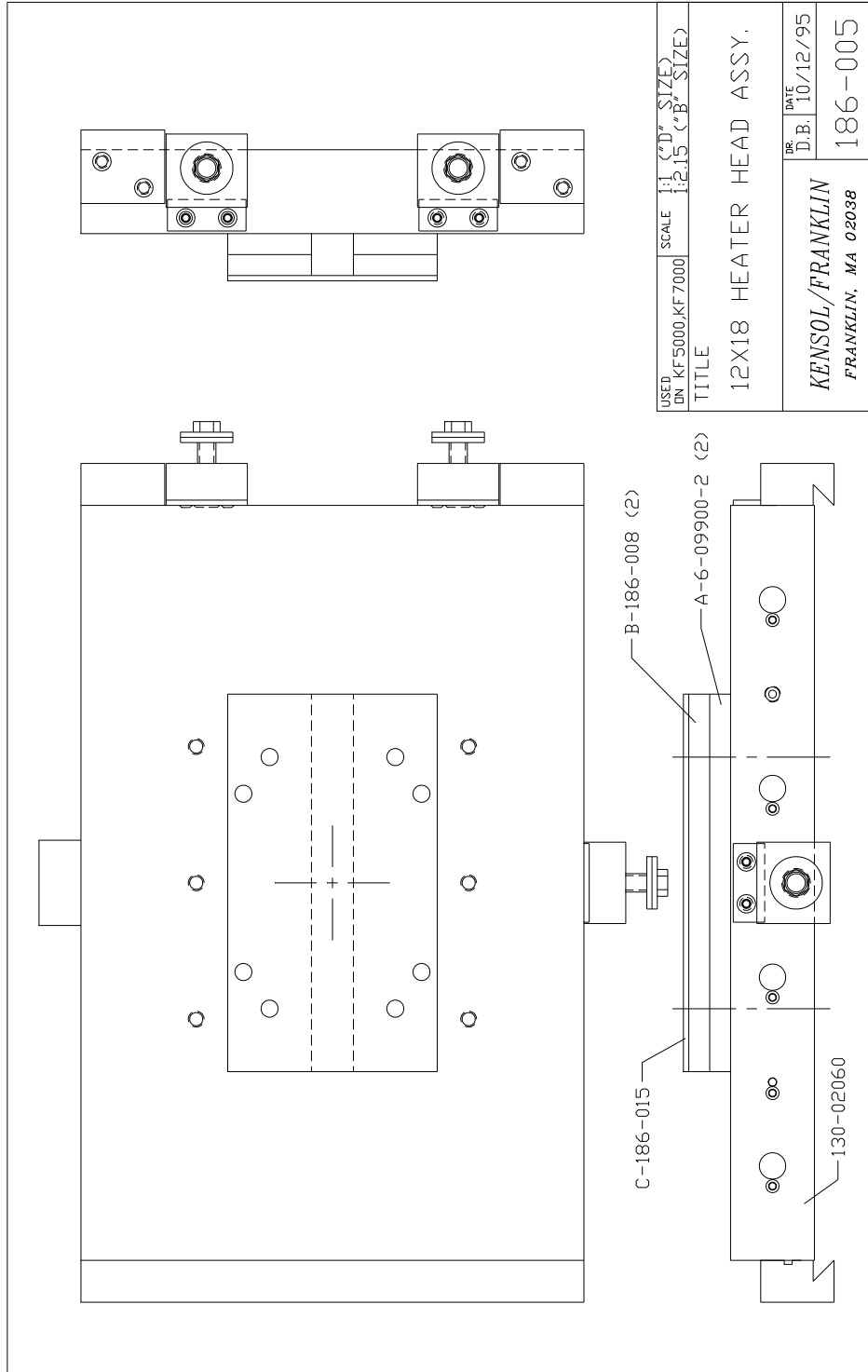

USED DN KF5000,KF7000	SCALE 1:1 (<D> SIZE) 1:2.15 (<B> SIZE)
TITLE 12X18 HEATER HEAD ASSY.	
DR. DATE D.B. 10/12/95	
KENSOL/FRANKLIN FRANKLIN, MA 02038 186-005	

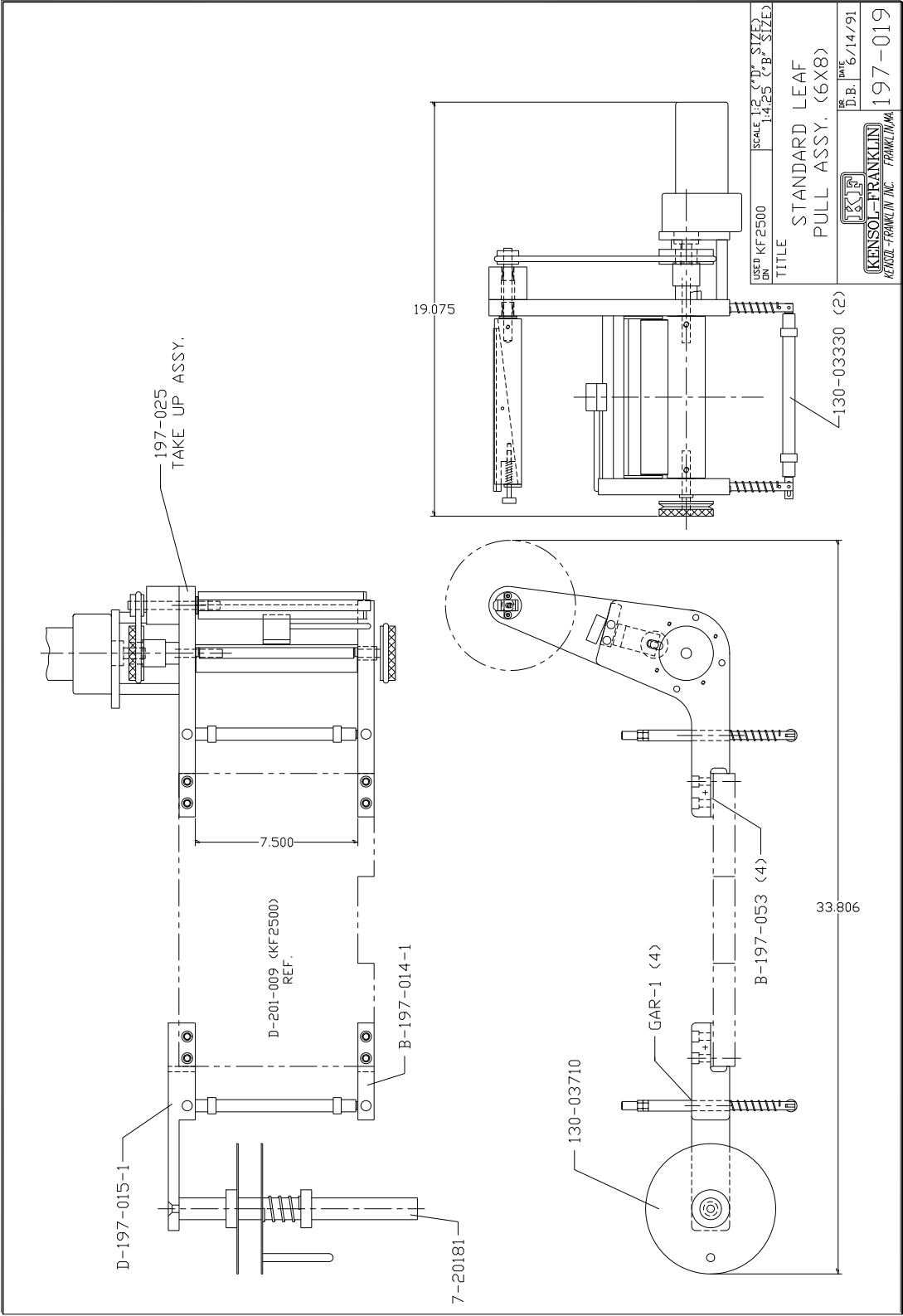

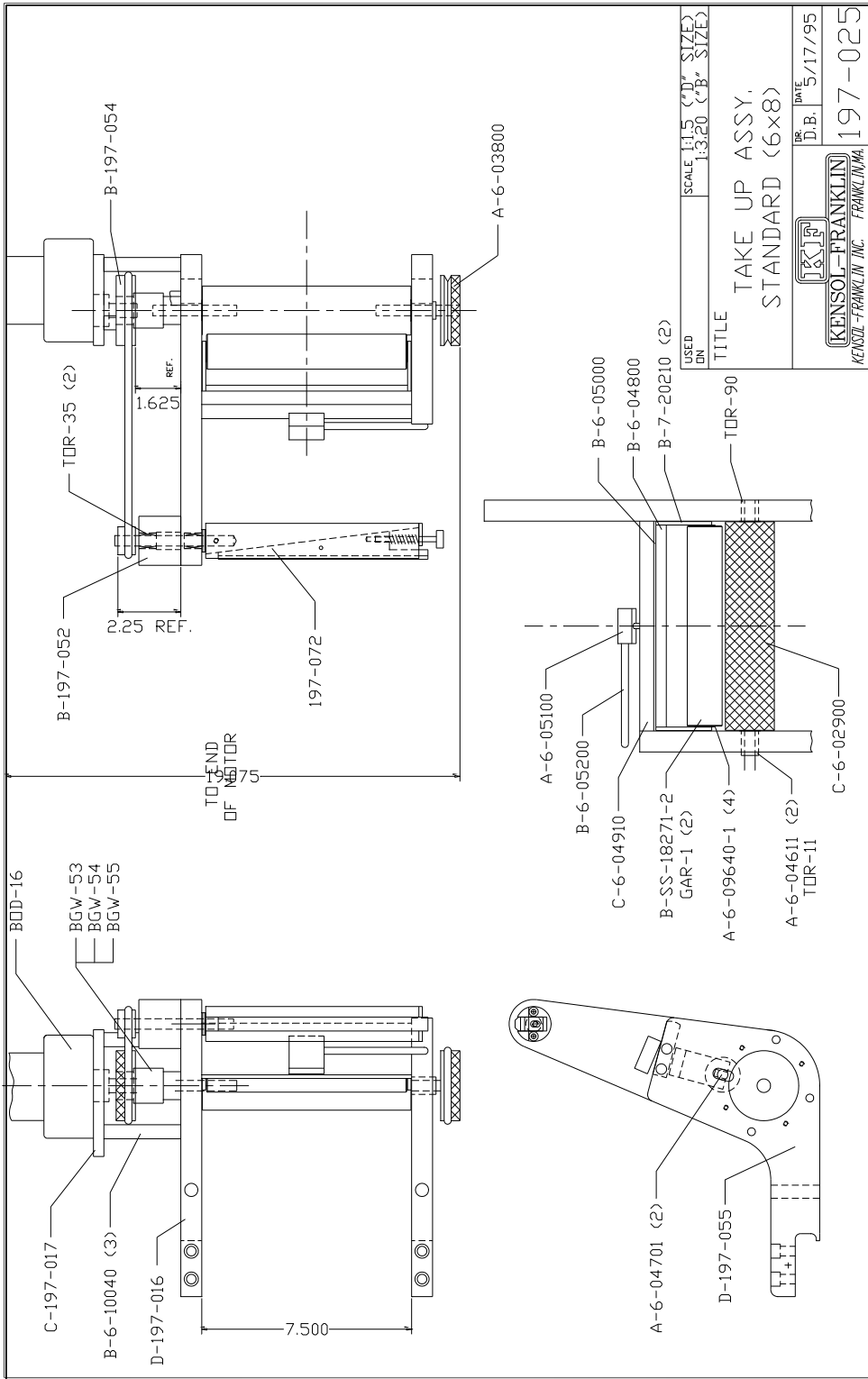

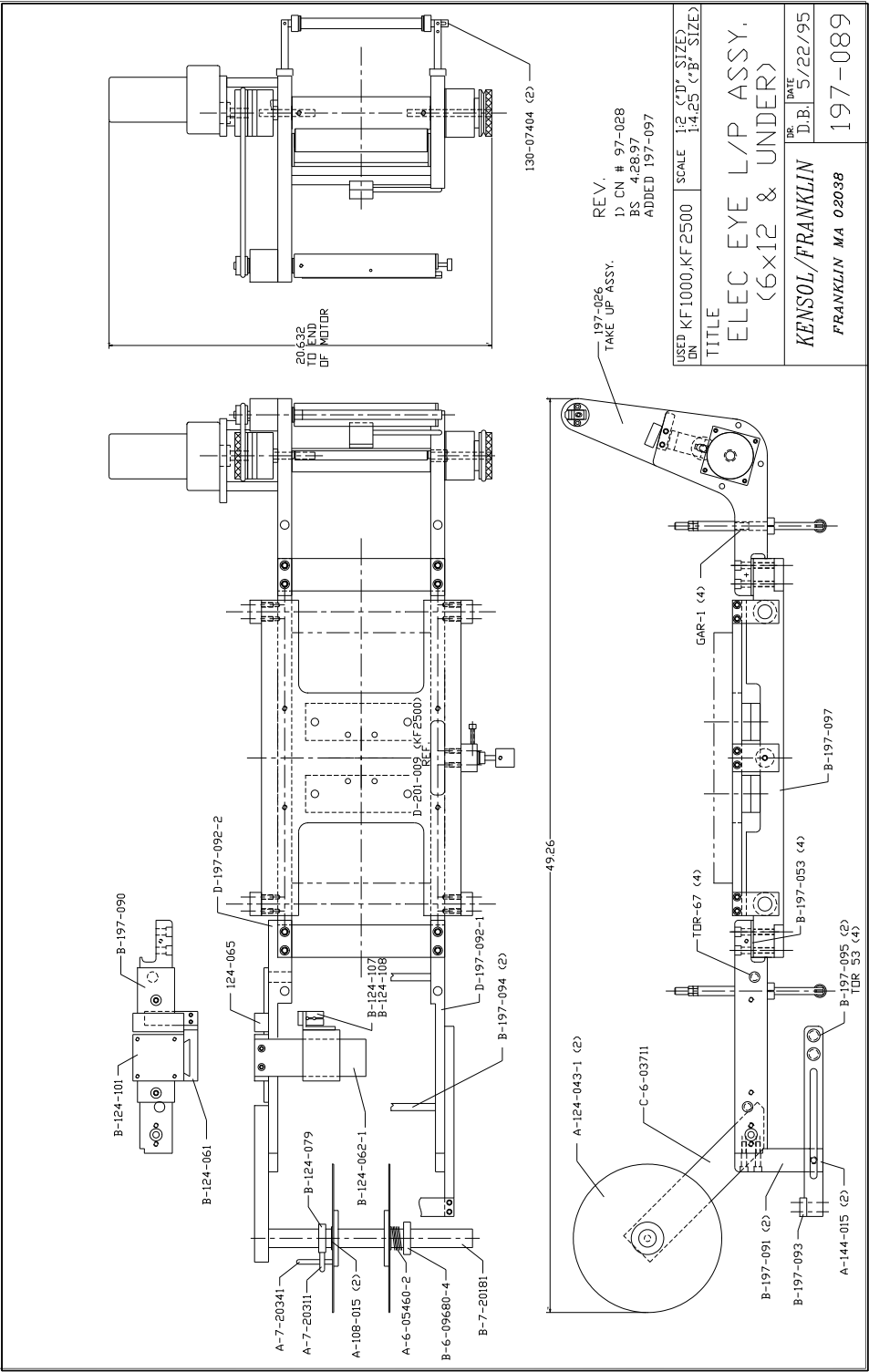

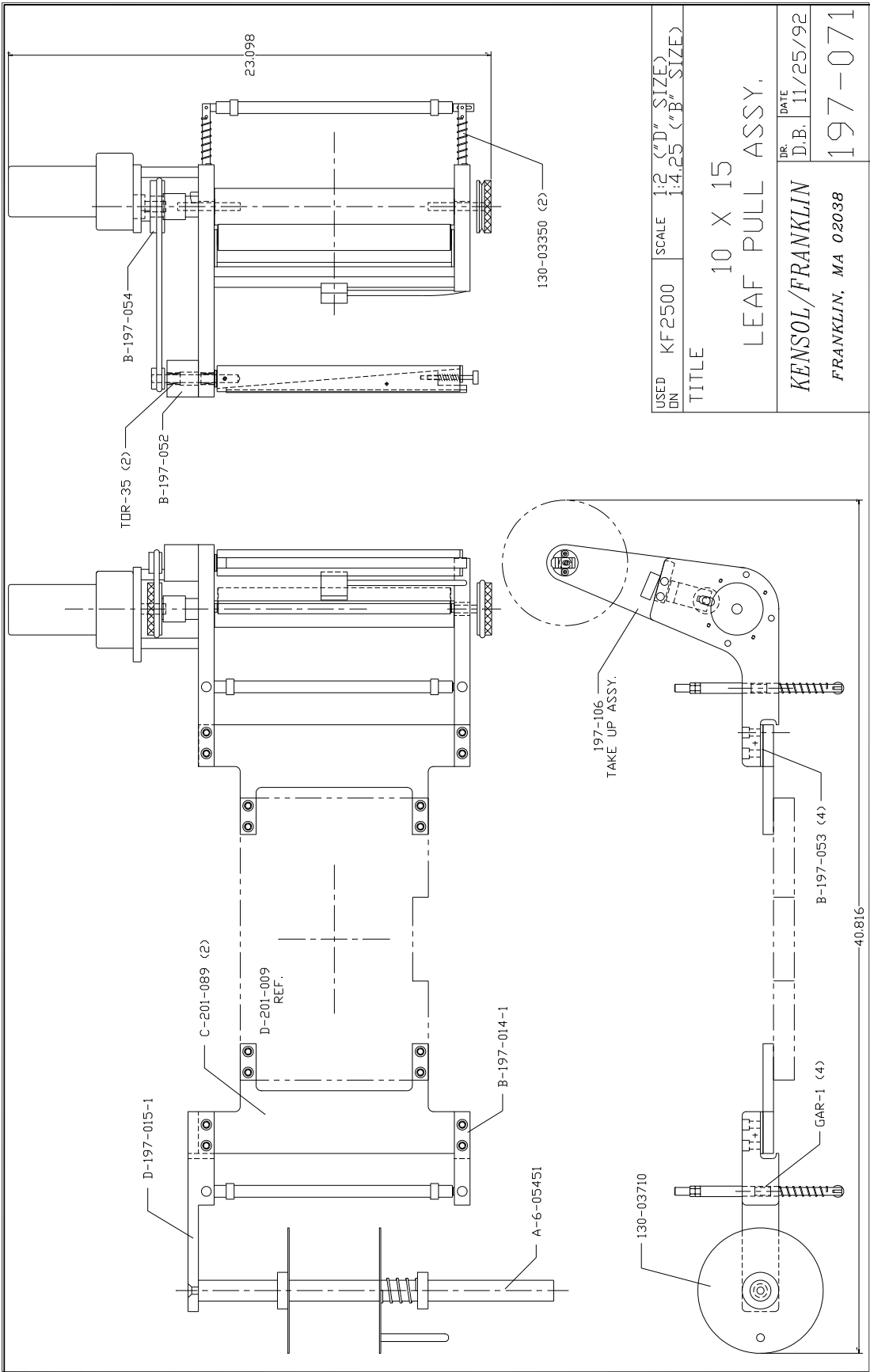

USED DN	KF2500	SCALE	1:2 ("D" SIZE) 1:4.25 ("B" SIZE)
TITLE 10 X 15 LEAF PULL ASSY.			
DR.	D.B.	DATE	11/25/92
KENSOL/FRANKLIN FRANKLIN, MA 02038			197-071



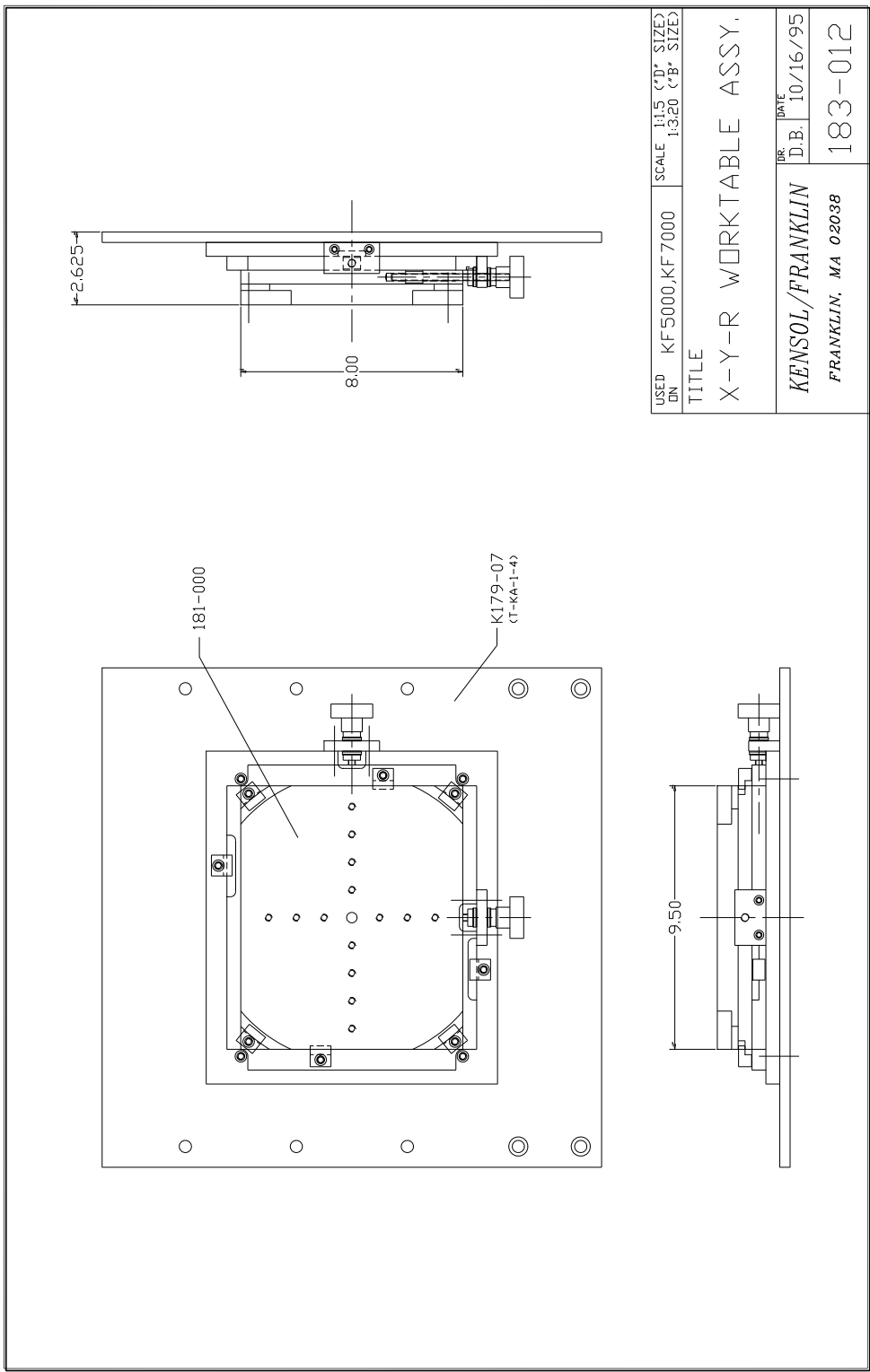

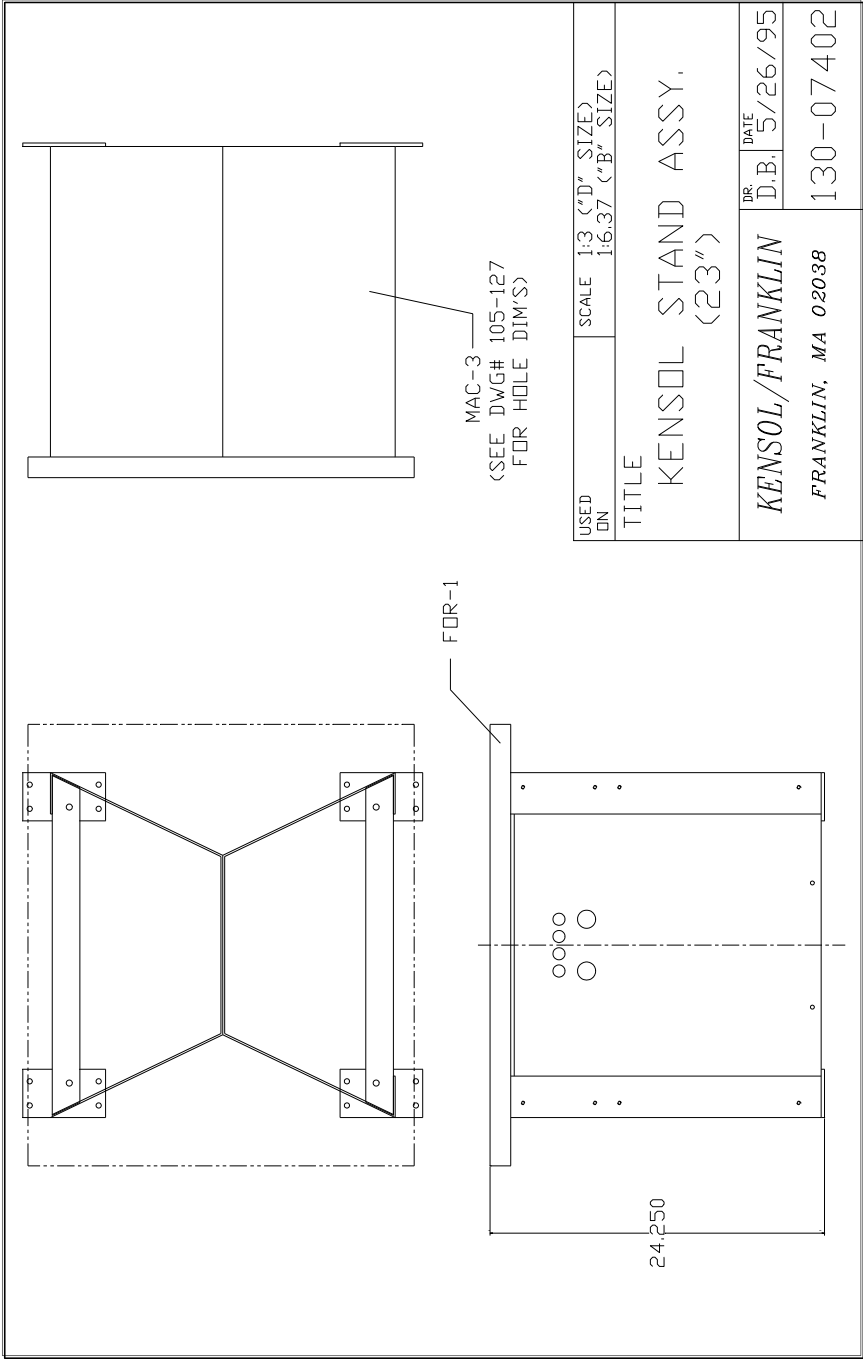

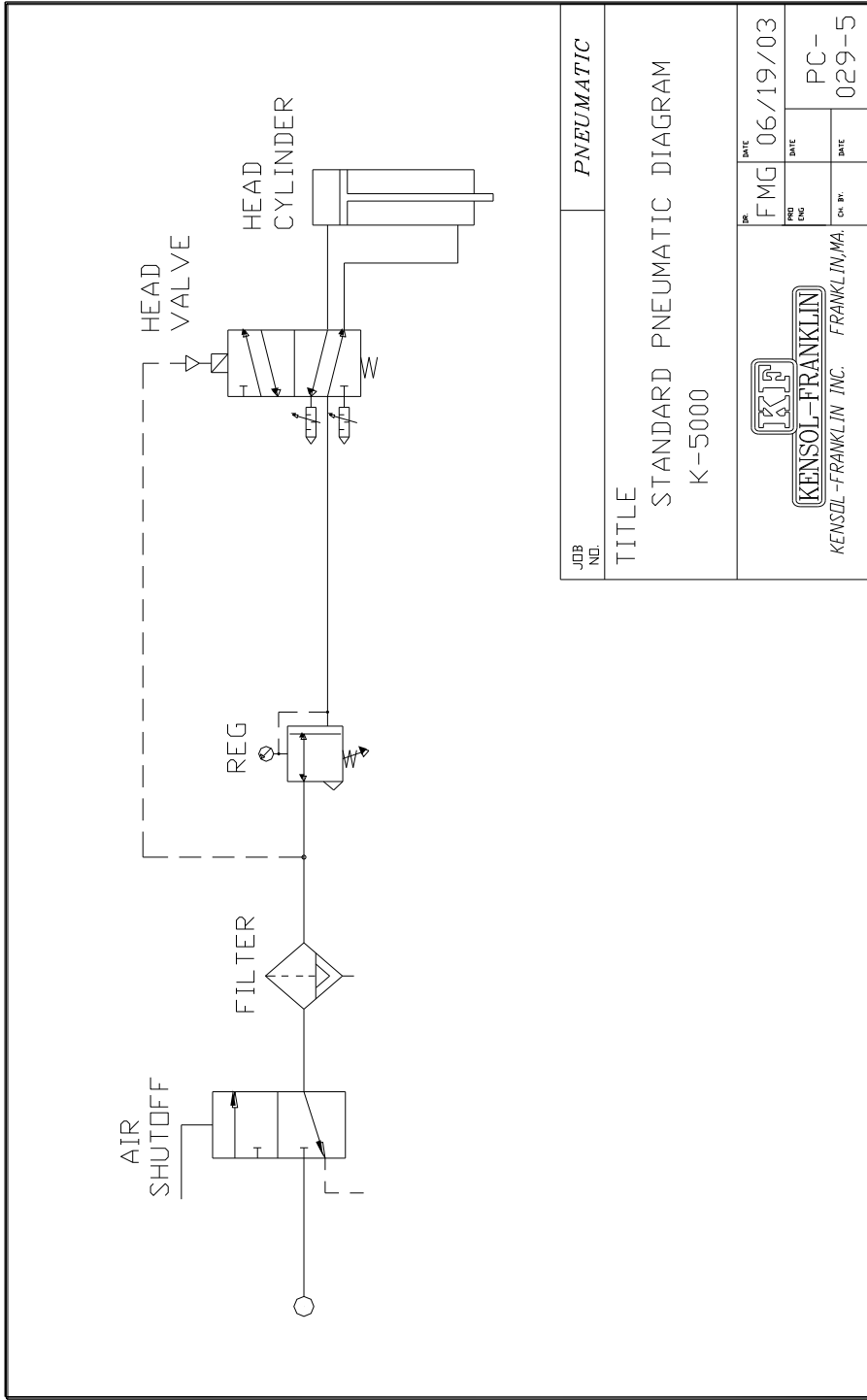

JOB NO.	<i>PNEUMATIC</i>		
TITLE	STANDARD PNEUMATIC DIAGRAM K-5000		
DR	DATE	CHK BY	DATE
FMG	06/19/03		
PC-			
029-5			



KENSOL-FRANKLIN INC. FRANKLIN, MA.